



Scotchkote™ Spray System HSS-450

For Spray Application of 3M™ Scotchkote
Liquid Epoxy Coating 323

Cartridge Installation

Prior to setup and use:

- Read the 3M™ Scotchkote™ Liquid Epoxy Coating 323 Parts A and B MSDSs, labels and product data sheet.
- Select and use personal protective equipment based on exposure assesment of the specific application situation.

Disposal of product related waste

Refer to Section 13 of the 3M™ Scotchkote™ Liquid Epoxy Coating 323 Parts A and B MSDSs and applicable regulations or authorities for waste disposal.

1.0 Install Cartridge In Applicator

- 1.1 Attach appropriate mix nozzle to cartridge according to the instructions supplied with the nozzle.
- 1.2 Before installing cartridges into gun, hold gun in a vertical position pointing in a safe direction away from yourself and other personnel. This will reduce the chance of material drooling into the mixer bell housing causing premature cure of material in mixer.
- 1.3 Place the large end of the cartridge assembly (piston seal end) over the two ejector plates of the applicator, pushing the cartridge assembly towards the air cylinder, snapping the cartridge into place. Ensure that the cartridge assembly is properly seated in cradle of gun and ejector plates and rod assembly are properly aligned in applicator.

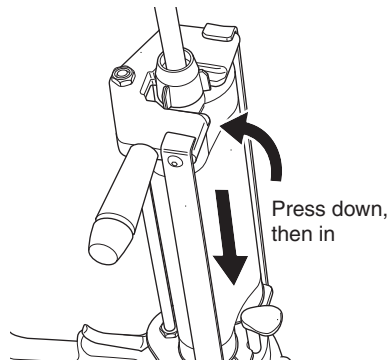

- 1.4 Attach elbow connector on nozzle air hose firmly onto the nozzle inlet.

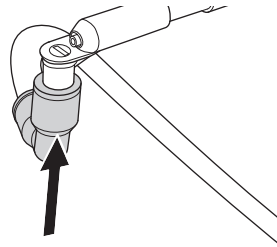

Attach
90° elbow
connector

2.0 Remove Cartridge From Applicator

- 2.1 While pressing the air return button, pull the trigger to retract the ejector plates from the cartridge.

Push to retract ejector plates

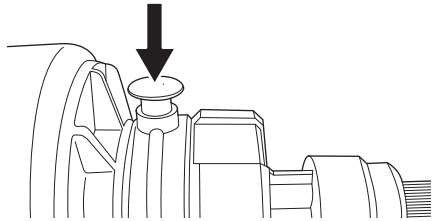

OR,
Push the return pusher toward the air cylinder to retract the ejector plates from the cartridge.

Push to retract ejector plates

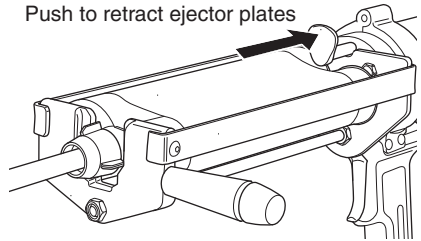

- 2.2 Remove the air supply hose from the regulator.

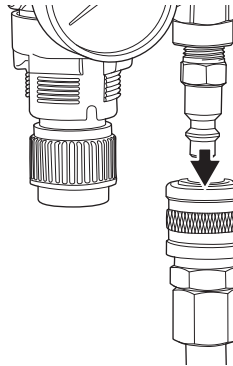

Remove Air
Supply Hose

- 2.3 Remove the elbow connector on nozzle air hose from the nozzle inlet.

Note: Do not discard the 90° elbow connector. It is not necessary to remove the connector from the nozzle air hose.

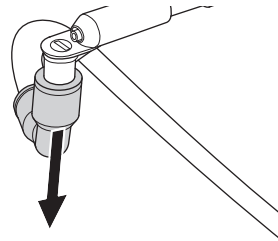

Remove
90° elbow
connector

- 2.4 While holding back the return pusher, push the cartridge assembly towards the air cylinder and lift out of the applicator cradle.

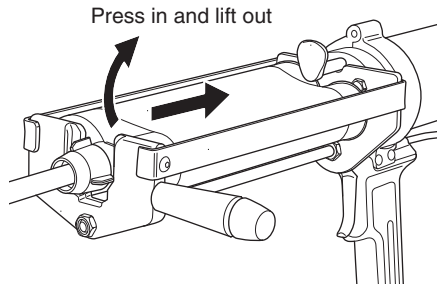

- 2.5 Partially-used cartridges may be reused by removing and discarding the nozzle and resealing the cartridge with the original plug. Be sure to re-align the plug according to the A and B compounds.

Note: Refer to Section 13 of the 3M™ Scotchkote™ Liquid Epoxy Coating 323 Parts A and B MSDSs and applicable regulations or authorities for waste disposal.

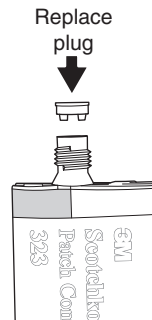

3M and Scotchkote are trademarks of 3M Company.

Important Notice

All statements, technical information, and recommendations related to 3M's products are based on information believed to be reliable, but the accuracy or completeness is not guaranteed. Before using this product, you must evaluate it and determine if it is suitable for your intended application. You assume all risks and liability associated with such use. Any statements related to the product which are not contained in 3M's current publications, or any contrary statements contained on your purchase order shall have no force or effect unless expressly agreed upon, in writing, by an authorized officer of 3M.

Warranty; Limited Remedy; Limited Liability.

This product will be free from defects in material and manufacture for a period of one (1) year from the time of purchase. **3M MAKES NO OTHER WARRANTIES INCLUDING, BUT NOT LIMITED TO, ANY IMPLIED WARRANTY OF MERCHANTABILITY OR FITNESS FOR A PARTICULAR PURPOSE.** If this product is defective within the warranty period stated above, your exclusive remedy shall be, at 3M's option, to replace or repair the 3M product or refund the purchase price of the 3M product. **Except where prohibited by law, 3M will not be liable for any indirect, special, incidental or consequential loss or damage arising from this 3M product, regardless of the legal theory asserted.**



Corrosion Protection Products

6801 River Place Blvd.
Austin, TX 78726-9000
www.3M.com/corrosion

Please Recycle. Printed in USA.
© 3M 2007. All Rights Reserved.
80-6111-8422-9